

MOMS type motor 32mm Ø

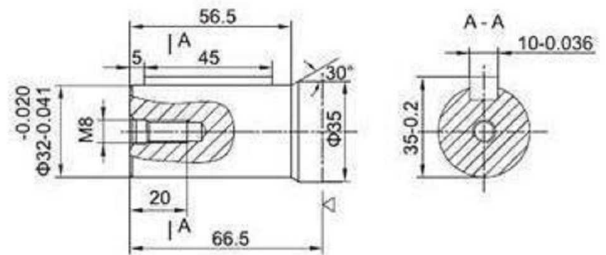
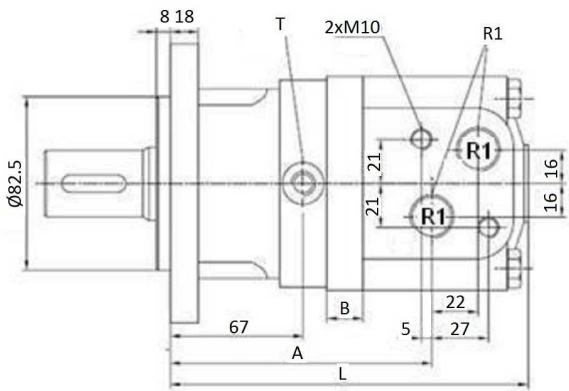
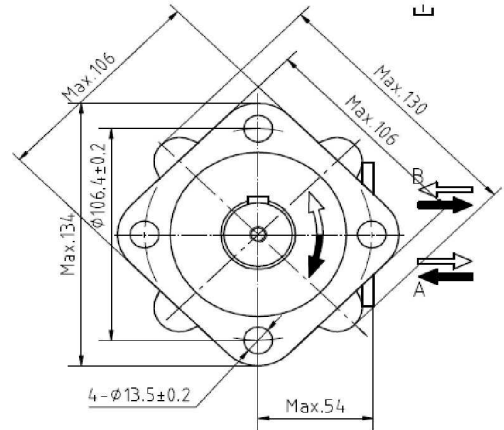
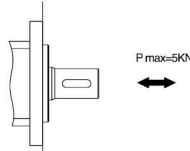
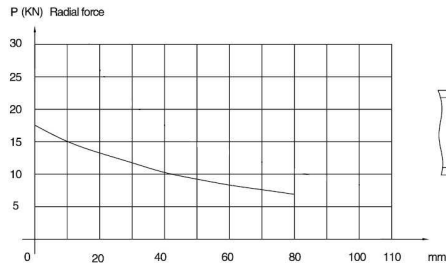

Shaft: cylindrical shaft, diameter 32 mm

Max. flow intern.: MOMS80 =80 (l/min); Others=90 (l/min)

T: drainage line, thread 1/4"

(Power in kW)

(Torque in daN.m)

Part n°	R1	Max. flow (l/min)	Max. press. cont.	Max. press. interm.	Max. Peak press.	cm ³ / rev	R.P.M. cont.	R.P.M. int.	Max. torque cont.	Max. torque peak	Max. power cont.	A	B	L
MOMS80	1/2" BSP	65	175	200	225	80.5	805	1.000	19,8	26	16	124	11	167
MOMS100	1/2" BSP	75	175	200	225	100.5	745	900	24,4	32,2	18	127	14,5	170
MOMS125	1/2" BSP	75	175	200	225	126.3	590	718	30,7	40,5	18	132	19	175
MOMS160	1/2" BSP	75	160	200	225	160.8	465	560	34	48,5	18	138	25	181
MOMS200	1/2" BSP	75	160	200	225	200.9	370	447	39,5	64,8	18	145	32	188
MOMS250	1/2" BSP	75	120	160	200	252.6	230	360	45	68	18	154	41	197
MOMS315	1/2" BSP	75	120	160	200	321.5	185	290	54,1	84	17	166	53	208
MOMS400	1/2" BSP	75	100	140	175	401.9	155	230	58	85	11	180	67	222

*** Review attached PDF***

*Intermittent operation rating applies to 6 seconds of every minute.

*Peak load rating applies to 0.6 seconds of every minute.