

Control valves

Manual control valves

Control valve 3/8 BSP, 45L/MIN, handle operated and return to center by spring. Relief valve

Page: 1/1

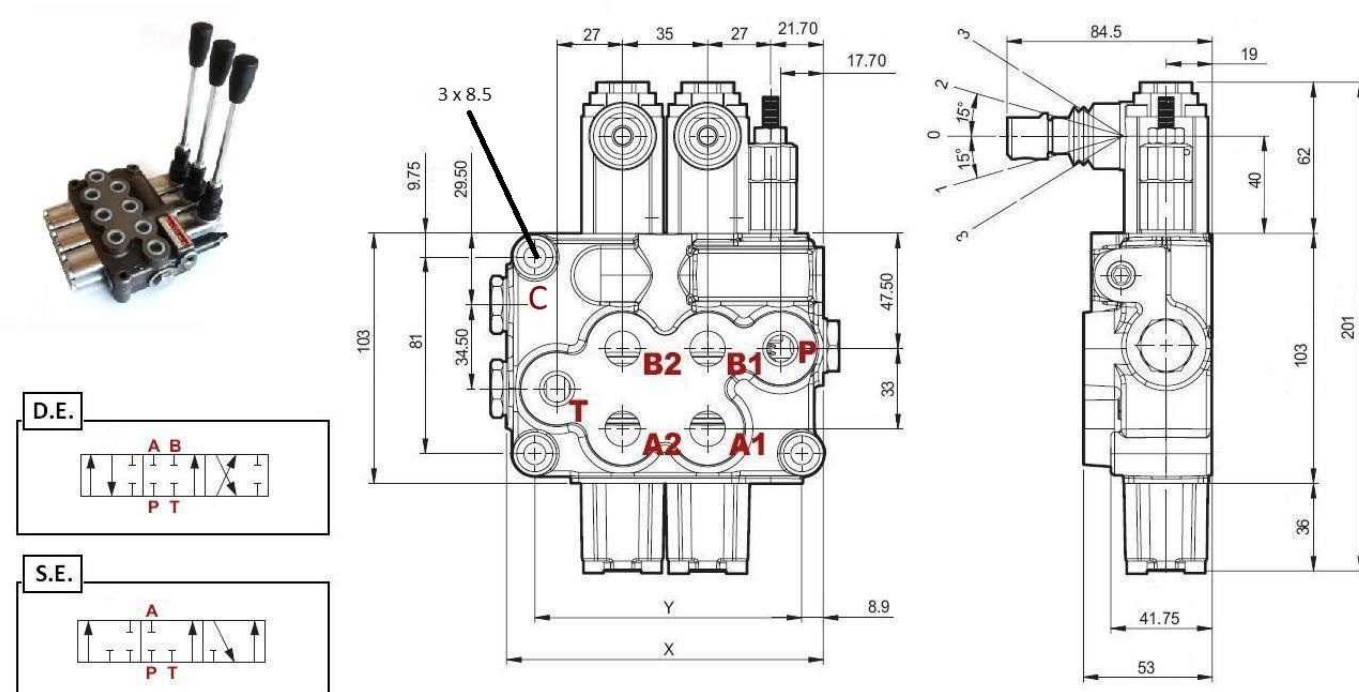

Max. Flow Rate 45 l/min

Operating Pressure (Maximum) 315 bar

Back Pressure (Maximum) on T port 25 bar

Ports 3/8" BSP

Relief Valve 140 bar (60-200 bar)

R1: A,B,P,T

Seal kit x slider 15.54x2mm (2 units)

Part n°	R1	Type	Max. flow (l/min)	Max. Press. (bar)	Levers	X	Y
YFM35/1 3/8 1P DE	3/8" BSP	D	45	315	1	93,5	73
YFM35/1 3/8 1P SE	3/8" BSP	S	45	315	1	93,5	73
YFM35/2 3/8 2P DD	3/8" BSP	D-D	45	315	2	130,5	110
YFM35/2 3/8 2P DS	3/8" BSP	D-S	45	315	2	130,5	110
YFM35/3 3/8 3P DDD	3/8" BSP	D-D-D	45	315	3	165,5	147
YFM35/3 3/8 3P DDS	3/8" BSP	D-D-S	45	315	3	165,5	147
YFM35/4 3/8 4P DDDD	3/8" BSP	D-D-D-D	45	315	4	202,5	184
YFM35/5 3/8 5P DDDDD	3/8" BSP	D-D-D-D-D	45	315	5	239,5	221
YFM35/6 3/8 6P DDDDDD	3/8" BSP	D-D-D-D-D-D	45	315	6	276,5	258